

Autonomic energy supply distribution networks with low pressure gas expansion engines

Vladislav Karasevich, PhD, Executive Director at JSC Lores, Moscow, Russian Federation

Alexey Yakovlev, Deputy Director General at JSC Kalugagrazhdanproekt, Kaluga, Russian Federation

Alexander Chernykh, senior expert at JSC Lores, Moscow, Russian Federation

Arkadiy Geraschenko, senior expert at JSC Lores, Moscow, Russian Federation

Keywords: gas expansion engine, gas distribution, autonomous energy supply

Background

Gas distribution plants require electric power to run the technological equipment, such as electrochemical protection, automation systems, telemechanics, control and regulation systems, heating, local lighting etc.

Power supply of most gas distribution stations and regulation points that are located near towns, or close to them, is generally made by local electric grids with autonomous diesel generator support if needed. Nevertheless, the high grid connection costs and long transmission lines construction are an issue for newly built gas distribution plants. The power capacity of these stations is generally not high – from 1 to 10 kW. This is the reason why autonomous power supply of these plants is a contemporary task.

The excessive gas pressure on gas distribution plants and regulation points is regulated by throttling. A special reduction unit, though, could use this pressure, – a gas expansion engine that is installed in the bypassing line of the throttle – to generate power, making it a fuel-free power generating technology.

The gas expansion engine is a unit, which converts the kinetic energy of the transported natural gas into mechanical energy by rotating the gas expander, which, in its turn, generates power in the generator. It is also possible to produce heating power of different temperature levels (alongside with electric power) if it is required for different heating or air conditioning needs.

The specs

The consumers of electric power of gas distribution plants and regulation points mostly require low-voltage power at 12 – 28 V. In general, step-down transformer units are used, alongside with batteries as a reserve. The power reliability of these systems is high, but they still require connection to a local electric grid.

The proposed power generating gas expansion engine can supply the consumers with up to 1 kW of electric power completely autonomously. This solution has the following advantages:

- Continuous autonomous power supply.
- Zero-emission power generation since no natural gas is burned
- The unit is included in the technological design of the gas distribution/regulation unit
- The range of capacity varies from 0.5 to 5 kW
- The unit can be a source for DC (12-24V) and AC (230V) consumers simultaneously

- The unit is delivered ready for use and can be modified to fit the needs of every gas distribution/regulation plant
- Low O&M costs and good overhaul ability since use of widely available materials and components

The specifications of the proposed unit:

- Gas inlet pressure – up to 1.2 MPa.
- Minimum gas inlet pressure – 0.08 MPa
- Gas flow rate – 60–100 cm³/h
- Nominal power capacity – 1000 W
- Nominal DC voltage – 28 V
- Maximum current – 36 A
- Optional use of 230 V inverting converter
- Nominal RPM – 5000
- Maximum RPM – 6000
- Dimensions – 600x300x350 mm
- Weight – ca. 40 kg

Control circuit

The mechanical part of the unit consists of rotary gas expander, which has low weight, small dimensions and low noise levels, and a synchronous fetlock-less AC generator. The torque is transferred through a rubber-metal flexible joint with a transfer coefficient 1:1. The electric part of the unit consists of the following parts: rectifier assembly with short circuit protection in the generator circuit; integral voltage regulator, which keeps the outlet voltage at a given level; act noise filter; control and protection unit; battery unit with charge level control; inverting converter for 230 V @ 50 Hz; external load switching unit.

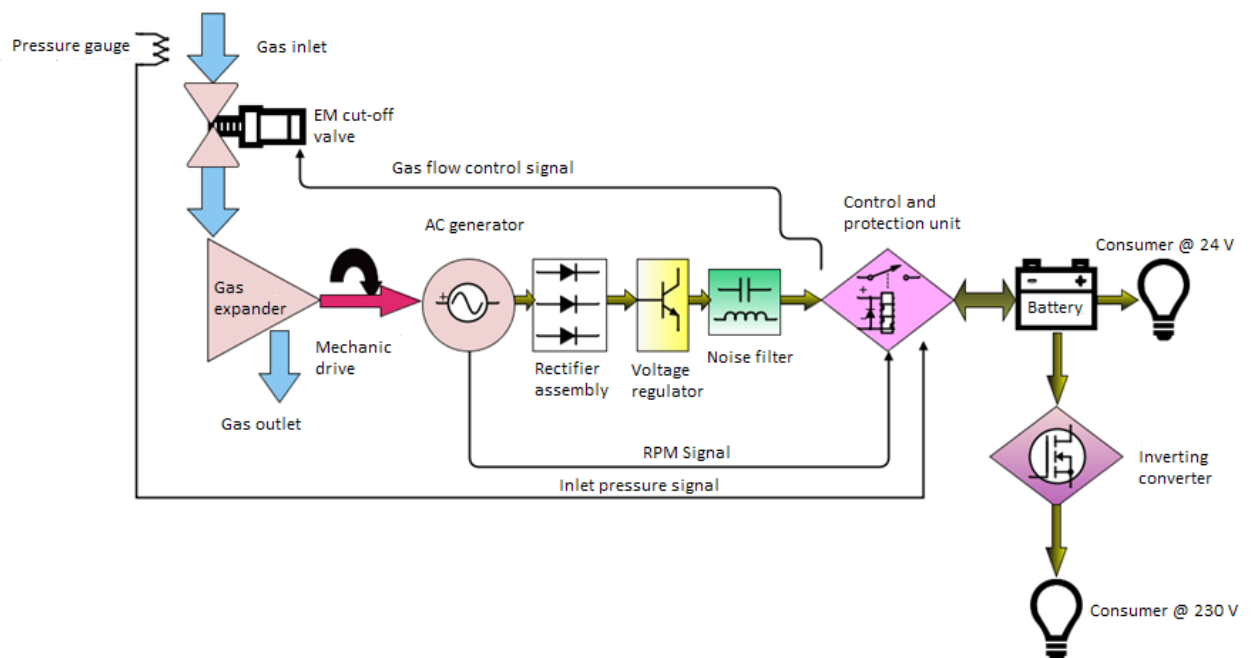

The control and protection unit provides normal functioning of the whole unit by keeping inlet and outlet parameters at given levels: gas inlet over-pressure protection; excessive rotating

speed protection; voltage surge protection. The inlet gas flow is regulated by an electromagnetic explosion-proof valve.

Conclusion

The low-pressure gas expansion engine is a perspective solution for autonomous power supply of remote gas distribution and regulation points.