



Emerging Technologies In the Gas Industry

Marie-José FOURNIGUET, GDF SUEZ

WGC2012 Youth Conference
6th June 2012



Question



Do you think the gas industry is innovative?

The research centers location



1,100 researchers
9 research centres

Investments in R&I: **€231** million
3,100 patents

5 strategic corporate programmes

Technology, a critical success factor for the Group
R&I, a gateway to technology

3 R&I priorities for GDF SUEZ in line with the Corporate Strategy

- ❑ **Decarbonized energy production**
 - CCS
 - Renewable energies

- ❑ **Smart Energy & Environment**
 - Building the cities of tomorrow
 - Smart metering & grids

- ❑ **LNG Off-shore and future gas chains**
 - Access new gas supplies
 - Transformation and transportation



5 major Corporate Programs

→ Based on the information from a deep Technology Watch, 5 Corporate Programs have been designed: major innovative domains requiring coordination and considerable investments at the Corporate level.



Capture, transport and Storage of CO₂



Offshore LNG and future gas chains

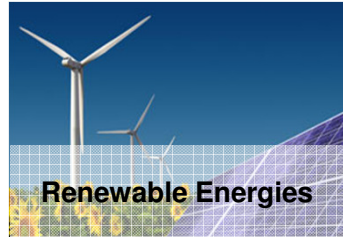

Renewable Energies



Smart Energy & Environment



City & building of Tomorrow

Involvement in pilots and demos:
Nijmegen in NL: tests on post-combustion capture

Road project in NL: capture, transport and storage

Fields:
 Access new gas supplies (conventional gas, shale gas, coal bed methane), LNG,

Alternative gas uses (gas to H₂, GTL, gas to wire)

Involvement in pilots and demos:
Mejillones in Chile: Concentrated Solar Power Project

GAYA in France: biomass gasification plant

Fields:
 Smart metering/grids, decentralized energy storage

Involvement in pilots and demos:
GreenLys in France: smart grid large scale demonstrator

Fields:
 Innovative building solutions,
 Sustainable mobility,
 Urban nature,
 Consumers behaviors

125 cm³ scooter fuelled with fast "plug-in" CNG cartridges



Source: GDF SUEZ (2010)

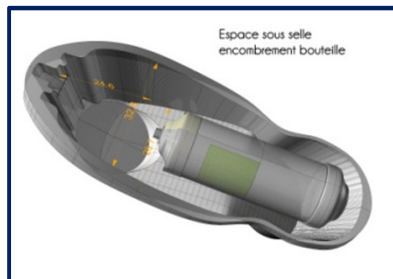
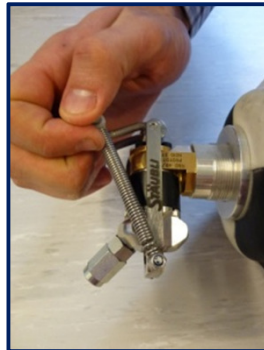

System description:

- 125 cm³ bi-fuel scooter (CNG/Gasoline)
- CNG cartridge: 6,8 litres / 4kg
- Fast "plug-in" connection
- CNG cartridge integrated under the saddle

Performances:

- CO₂/km (-26% vs. gasoline version)
- NO_x/km (-39% vs. Gasoline version)
- Autonomy: 300km gasoline + 55km CNG

EV pick-up with range-extender powered by CNG/biomethane *Plug-in CNG series hybrid concept-car*



Partnership GDF SUEZ, FAM Automobiles, France Craft

Concept-car description:

- EV pick-up (heavy quadri-cycle)
- Batteries Li-ion or Ni-MH
- Range-extender kit integrated underneath
- 2 fast "plug-in" cartridges under the trunk floor
- Autonomy targeted: 100 km on batteries + 100 km via CNG range-extender

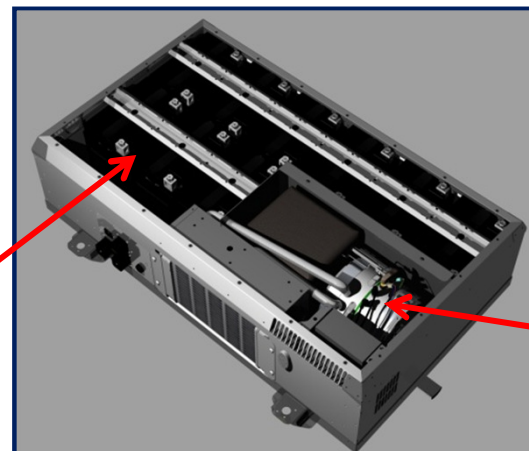

Batteries

**CNG
Range-extender**

LNG as a fuel: a solution for trucks, ships and barges

- *LNG trucks will fulfil with future Euro 6 standards and low CO₂ emissions targets*
 - ↳ *Since November 2011, GNVert (GDF SUEZ) participates to the 1st test on LNG trucks operated in France.*
 - ↳ *The “Blue Corridor”: a proposal for an European demonstration project to develop LNG filling stations across Europe*
- *LNG is an appropriate alternative for ships and barges, with limited impact on engines and operation, while allowing a reduction of SOx emissions.*
- *With LNG, CO₂ emissions can be reduced by 25%, SOx can be reduced by 100% and NOx emission can be reduced by 85%*



- New High Modulation Boiler : from the idea to the product**

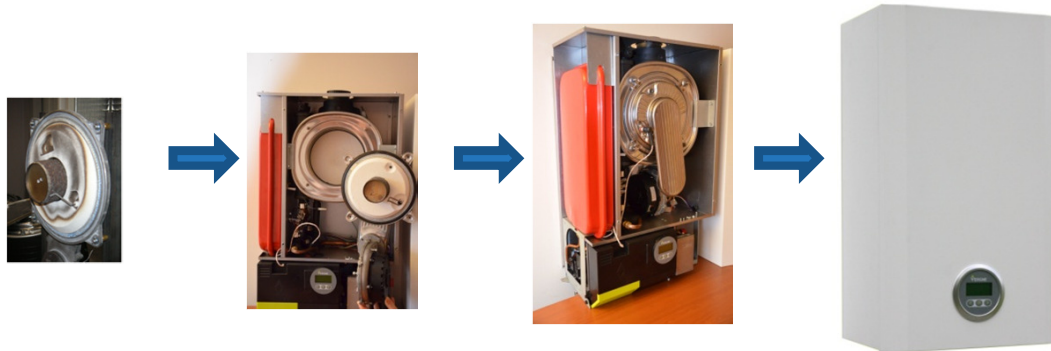

- Modulation: 0,8 to 28 kW at constant efficiency
- One patent pending
- 2 years of development

- Hybrid Boiler : when renewable reach gas products**

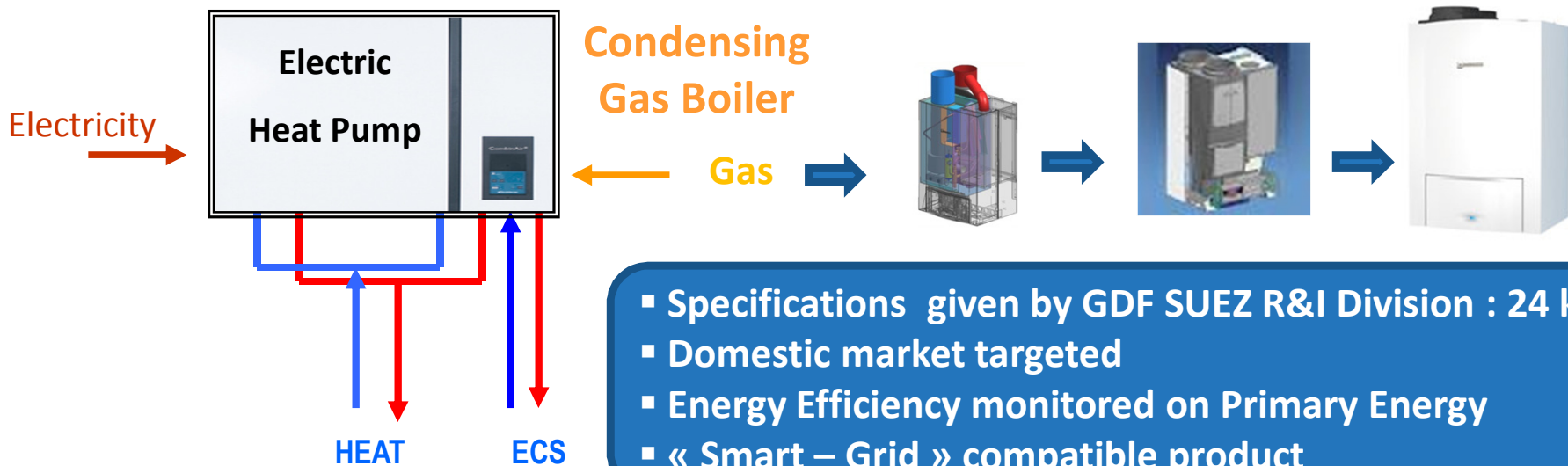

- Specifications given by GDF SUEZ R&I Division : 24 kW_{th}
- Domestic market targeted
- Energy Efficiency monitored on Primary Energy
- « Smart – Grid » compatible product

• New Combustion : Radiant Efficiency with Electricity

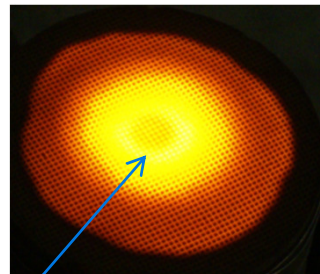
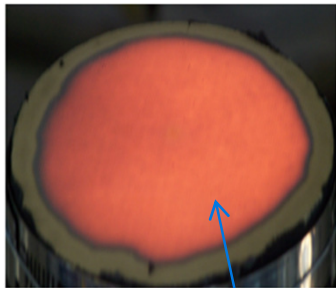

- A “4-Dimension” combustion: Gas + Air + Heat + Electricity
- One patent (2010)
- Efficiency: +8 to +15% vs. standard

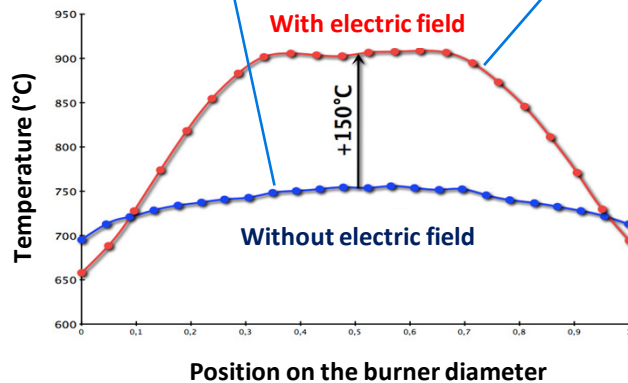

- R&D works planned in 2012:
- Laboratory tests
 - Simulations



New technologies to operate the gas networks/grids (1/2)

Gastracker™: Acoustic detector for PE gas pipe



From the gas box, send an acoustic wave into the gas pipe

Follow the vibration due to acoustic wave through sensors

Get the result immediately on a PDA



- Accuracy: (x, y) 10 cm
- Detectable length: 200 m
- Commercially available
- Cost : ~10 k€

UAV (Unmanned Aerial Vehicle) to identify threats to buried oil & gas transmission pipelines

- *Automated aerial surveillance of a gas transmission pipeline in 3 steps :*
 - ↪ *Image collection via a light UAV*
 - ↪ *Image pre-processing (geo-referencing)*
 - ↪ *Detection, identification and localization of external threats like excavations and undeclared work in pipeline ROW (right of way)*
- *Main technical challenge : reliability of image processing to avoid false alarms.*



- *From vineyard biomass to glass melting :*

- ↳ *Development of a Biogas Syngas Production Technology for Glass Melting Furnaces*
- ↳ *Xylowatt gasifier (1 MW fuel)*
- ↳ *Gasifier to be hooked up to Glass Melting Furnace under operation.*



- *Biomethane & Fuel-Cells:*

- ↳ *Fuel-Cell (SOFC & PEMFC) for cogeneration*
- ↳ *Test of biogas purification technologies*
- ↳ *Biomethane fed into Fuel-Cells*
- ↳ *Technical, economic & environmental assessment*



Power to gas: a smart technological breakthrough to store & transport electricity

- To achieve a low carbon energy system by 2050, including further penetration of RES, Europe needs to:

↳ *addresses the supply & demand issue to guarantee the stability of the electricity infrastructure*

↳ *creates flexibility to accommodate the surpluses of electricity from renewable sources*

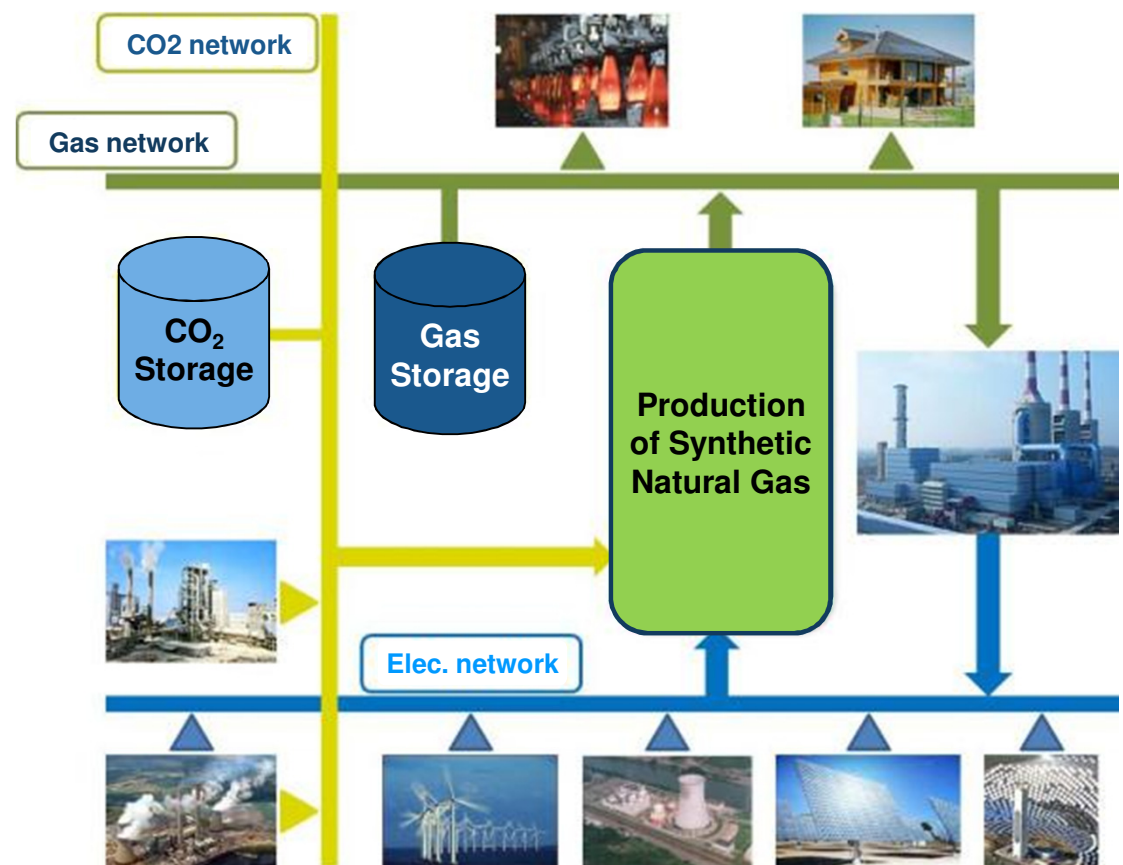

Wi-Fi wireless and no-maintenance sensors (P, T, Q)

- no-maintenance monitoring system : pressure/stress, temperature, flow-rate.
- no consumables, passive system, no batteries.

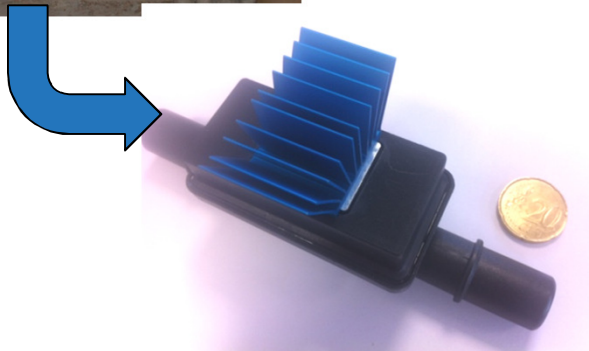

Ultra low-cost in-line gas analyser

- in-line, real-time, low-cost, low-maintenance gas flow analyzer : no sampling, small and fast system.

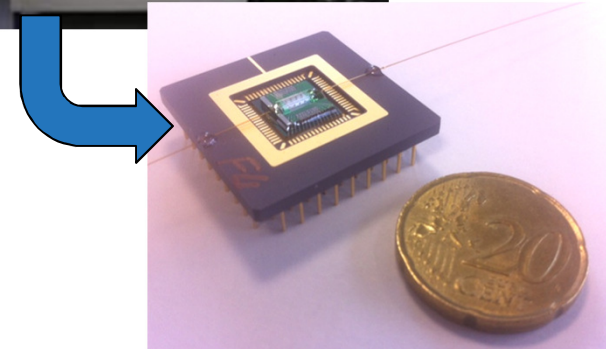

Discussions



- And so... Do you think the gas industry is innovative enough?
- In your opinion, do the presented emerging technologies fit with expectations at all levels? Private/professional? Targeted sectors?
- What do you expect from gas industries and their R&I Divisions in the future?
- What is for you a “Smart City”/the “Ideal City”?
- What are for you the major challenges for future generations?

Thank you for your attention!

GDF SUEZ

BY PEOPLE FOR PEOPLE

Contact: marie-jose.fourniguet@gdfsuez.com